

## PRODUCT DATA SHEET

Exclusive design for immediate, early or late loading. Original implant specially designed to meet the essential concepts in Osseointegration: "immobilization, fixation and primary stability".

The exclusive self-advancing / self-tapping thread design, placed in a small-sized socket, creates a close implant-to-bone contact thus ensuring maximum primary stability. Implants are manufactured in Titanium alloy Grade 5 (66% more resistant than Titanium Grade 2).

### Internal Hex Implant Presentation

DIAMETERS	LENGTHS (mm.)				
		10	11.5	13	15
Ø 3.50 mm.	-	10	11.5	13	15
Ø 4.00 mm.	8	10	11.5	13	15
Ø 4.70 mm.	8	10	11.5	13	-

Sterilized by Gamma Radiation.

They are packed in double tamper-resistant container that preserves sterility and facilitates handling, patient chart label included. **Implant mount can be used as transfer and provisional prosthetic abutment with fastening screw.**

### THE IMPLANT IS DIVIDED INTO THREE SEGMENTS:

• **Intraosseous segment (a):** The diameter of the tip gradually narrows ending in a semi-sharp end for easy insertion of the implant.

• **Conical mid-segment (collar) (b):** 2 mm in height with microturns. Treated surface for better positioning of the epithelial attachment and the biological width.

• **Internal connection segment (c):** Compatible internal hexagon.

Features a threaded cavity where the different prosthetic parts are fixed. It is compatible with most prosthetic abutments for the internal hexagon system (compatible platform 4.0 mm).

### CRITERIA FOR PATIENT SELECTION:

- Healthy patients, suitable for surgery.
- Clinical, X-ray and computed-tomography studies, making of computed tomographic and surgical guides.

### SURGICAL INSTRUMENTATION REQUIRED:



## INTERNAL HEX

3.50 / 4.00 / 4.70 mm Ø

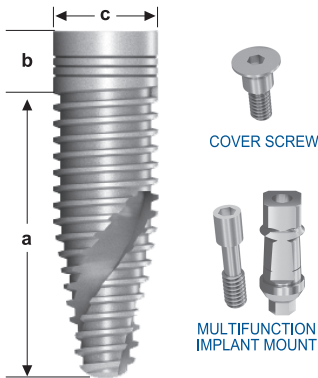

Odontit S. A.: [www.odontit.com](http://www.odontit.com) - [info@odontit.com](mailto:info@odontit.com)  
Tel. (54 11) 4825-0221 / Fax. (54 11) 4903-9330  
Azcuénaga 1077 4ºD / C1115AAE / C. A. de Bs. As. / Argentina

## INTERNAL HEX

3.50 / 4.00 / 4.70 mm Ø

### SURGICAL PROTOCOL:

- Determine number and position of implants to be placed.
- Expose the crest of the bone through incision of soft tissue with a punch or small flap, according to anatomical characteristics.
- Begin with a 2.00mm-diameter spade drill or drill through the cortical bone and then some millimeters into the medullary tissue. Confirm previous diagnosis on bone density.
- Proceed with the usual sequence increasing gradually the drill diameters until the indicated diameters for each case according to Chart N° 2 are reached.
- This technique is an innovation in the need to make a small socket. The diameter of the used drills varies according to the bone densities listed in Chart N° 2.
- Drills must reach a depth corresponding to the measures listed in Chart N° 3. According to this, the turns and the apical segment of the implant are inserted into intact bone, ensuring "immobilization, fixation, and primary stability".

CHART N° 2: Final diameter values of drills according to bone density (Lekholm and Zarb Classification).

IMPLANT & DIAMETER	CLASS 1	CLASS 2	CLASS 3	CLASS 4
Internal Hex 3.50 mm	3.30 mm	3.00 mm	2.80 mm	2.80 mm
Internal Hex 4.00 mm	3.50 mm	3.50 mm	3.30 mm	3.30 mm
Internal Hex 4.70 mm	4.30 mm	4.30 mm	4.00 mm	4.00 mm

CHART N° 3: Depth of sockets according to the length of the implants.

- 8.00 mm. implants \_\_\_\_\_ 6.00 mm.
- 10.00 mm. implants \_\_\_\_\_ 7.00 mm.
- 11.50 mm. implants \_\_\_\_\_ 8.50 mm.
- 13.00 mm. implants \_\_\_\_\_ 10.00 mm.
- 15.00 mm. implants \_\_\_\_\_ 12.00 mm.
- Once the drilling is complete, position the implant on the socket using the plastic holder.
- First thread by hand or placing an implant mount driver (Catalog #: IMDS). It must be operated at low RPM. If resistance offered by bone tissue stops manual or implant mount driver operation, use the ratchet wrench (Catalog #: RW) or the open end wrench (Catalog #: OEW4) until complete implant insertion is achieved.
- Once the implant placement is finished, remove the implant mount using a screwdriver (Catalog #: THDL48) and, depending if it is a one or two-stage surgery, a healing

abutment is threaded over the implant (Catalog #: HH2, HH4) abutment is threaded over the implant (Catalog #: HH2, HH4).

- In the case of immediate loading, the prosthetic abutment is threaded on the implant chosen.
- The provisional plastic prostheses must be placed in sub-occlusion without any side contact.
- Cement provisional prostheses with permanent cement and avoid removing them during the osseointegration process. For bruxer patients, make a miorelaxation plate.
- The osseointegration process lasts about two months for the jaw and about three months for the maxilla.
- Once the required time has passed, remove the provisional prosthesis. Make the final prosthesis following the usual methods and using the chosen materials.

**General considerations:** For additional information, please refer to the Implant System's Manual, printed version, or view the electronic version visiting [www.odontit.com](http://www.odontit.com)

